

# The Most Powerful Operator on the market

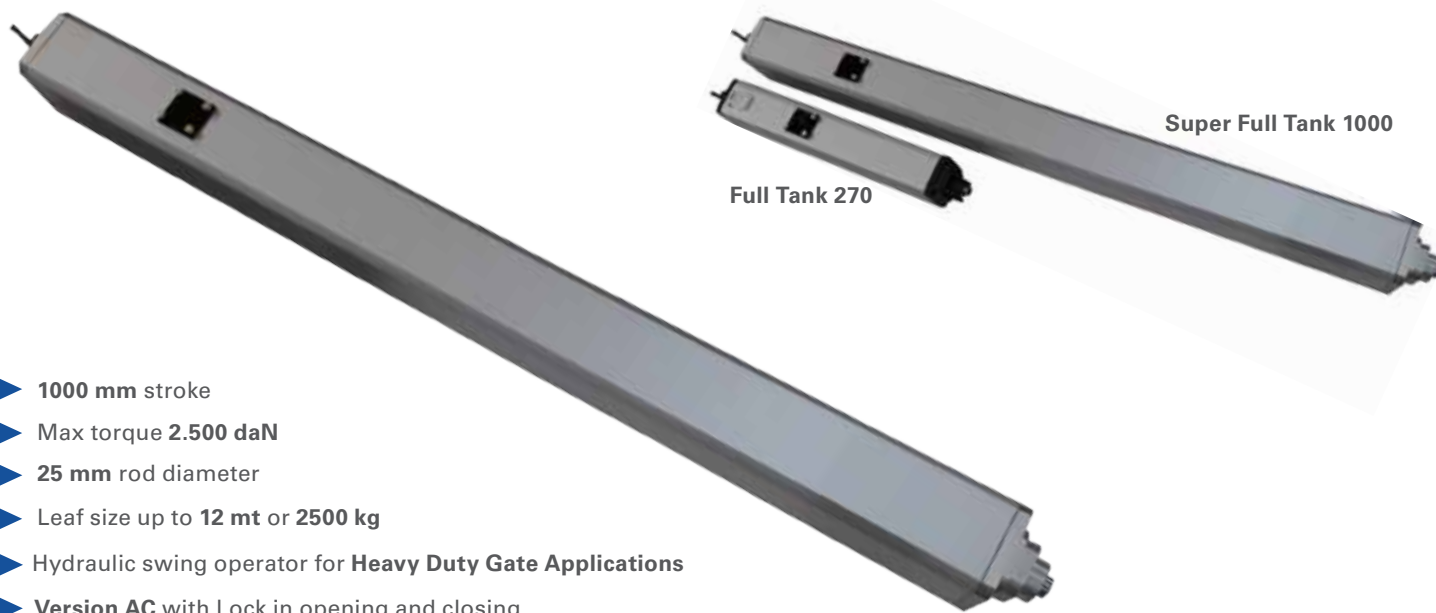

## SUPER FULL TANK 1000

Hydraulic Swing Gate Operator for condominium and industrial use max leaf length **up to 12 mt**



- ▶ 1000 mm stroke
- ▶ Max torque 2.500 daN
- ▶ 25 mm rod diameter
- ▶ Leaf size up to 12 mt or 2500 kg
- ▶ Hydraulic swing operator for **Heavy Duty Gate Applications**
- ▶ **Version AC** with Lock in opening and closing

WEIGHT	LENGHT	SPEED	CYCLES
2500 kg	12 mt	adjustable	continuous



Release system protected by metal lock with release key at the inside



Round joint for stroke adjustment



Front flange in solid machined aluminium



Back flange in solid machined aluminium

SPECIFICATIONS	SUPER FULL TANK
Power supply	230V (±5%) 50/60 Hz
Power Consumption (W)	310 W
Operating T° range (C°)	-20°C /+ 55°C
Opening time 90° (sec)	40 sec.
Cycles/hour	100
Duty	Commercial-industrial
Protection class	IP55
Max leaf length	12 mt / 40 feet
Max leaf weight	2.500 kg / 5.500 lbs
Max opening angle (degrees)	90°/120°
Maximum force output	2500 daNm
Anti-crushing protection	By pass/Electronic
Limit switch	-
Slowdown	Hydraulic
Battery backup	STAR 1000

# UNIGATE - I

## *INVERTER technology*

### UNIGATE 2I (INVERTER)

- Digital control unit with LCD display
- Adjustable speed
- Adjustable acceleration/deceleration
- Continuous motor cycles
- High strength in slowdown
- Possibility to manage obstacle reverse

#### Integrated functions on the UNIGATE INVERTER

- 2 relay contacts
- 2 programmable GPIO outputs
- LE card on board for potentiometer
- Relay card on board
- PROBE heater card on board
- Management of two FV inverters for 2 motors or 2 PM modules for 4 motors
- Timer on board with buffer battery and management of 2 time bands
- 2 Ah switching transformer of which about 1.3 Ah free for other accessories



## Advantages:

- + Duty cycles
- + Torque
- + Speed (adjustable)
- + one model 90V to 265V

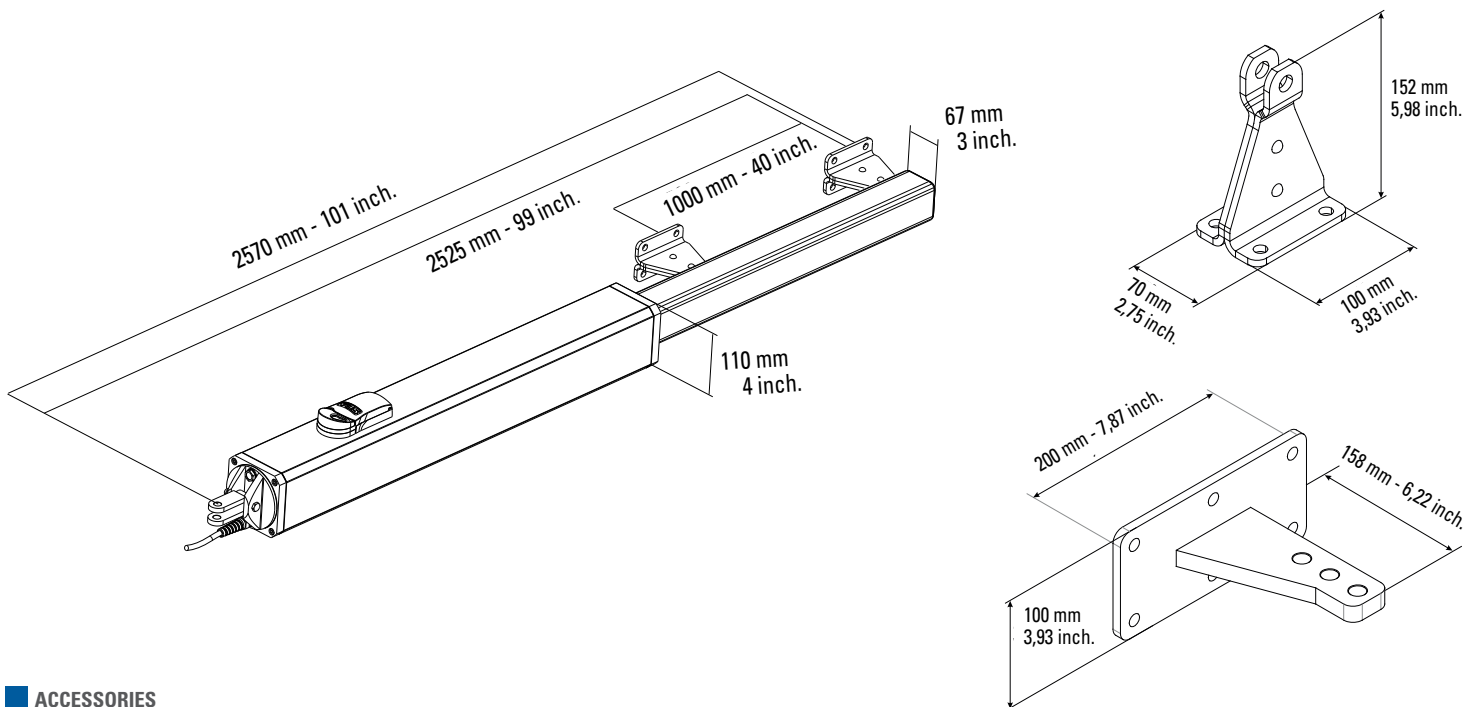

### ACCESSORIES

